

INDUSTRIAL SIRENS & SOUNDERS

MOTORISED LONG RANGE SIRENS

OVERVIEW

Durable all-weather aluminium siren with a hydraulic motor. Designed for applications where a siren is required and hydraulic oil pressure is available, i.e. hydraulic operated earth moving machines and other hydraulically operated equipment.

SIRENCO HYDRAULIC SIREN

- ❖ Sound output 117 dB(A) at 1m
- ❖ Low penetrating tone
- ❖ Weatherproof

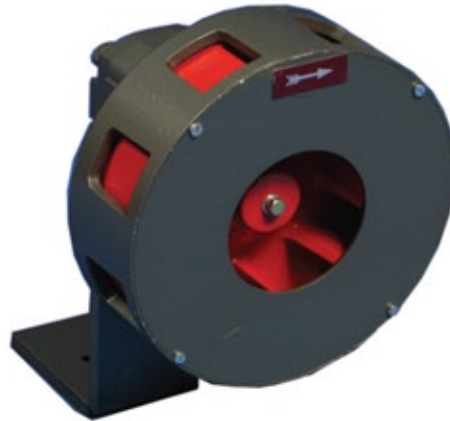

SPECIFICATIONS

VOLTAGE

Hydraulic motor

Sound Output:	117 dB(A) at 1m
Sound Frequency:	500Hz
Rating:	IP 65
Construction:	Aluminium
Dimensions(lxhxw):	165 x 145 x 285 mm
Weight:	4 Kg

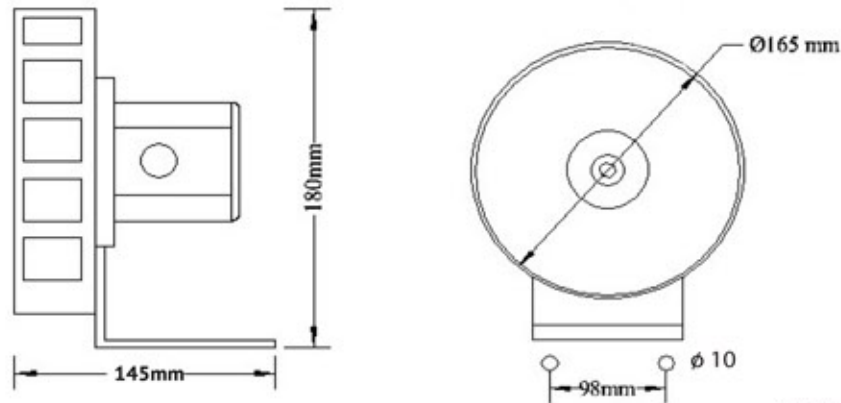

All Dimensions in mm

DETAILED SPECIFICATIONS

DUTY CYCLE	Continuously rated
SOUND OUTPUT	117 dB(A) at 1m
SOUND FREQUENCY	500Hz
APP. RANGE	1500m in still air on open field
MOTOR	Hydraulic
HYDRAULIC PRESSURE	240 bar max Continuous 27.5bar max - Intermittent
IP RATING	IP 65
WEIGHT	4Kg
PACKING DIMENSIONS	20 x 20 x 20 cm - 6Kg
MOUNTING	The unit should ideally be mounted in a horizontal position. In environments where dirt or particles may fall onto the moving parts of the siren's impellers, it is recommended to place a protective shield above the unit for protection.