

# INDUSTRIAL SIRENS & SOUNDERS

## MOTORISED LONG RANGE SIRENS

### OVERVIEW

All-weather enclosed motor is ideally suited for outdoor use. This siren would be used for audible warning at refineries, oil rigs, in the of fires and open - cast mining operations. This precision machined unit produces a powerful dual low frequency sound that is ideal for long distance signalling.

### SIRENCO 15D

- ❖ Sound output 145dB(A) 1m
- ❖ Dual rotor
- ❖ Low penetrating tone
- ❖ Weatherproof



#### SPECIFICATIONS

VOLTAGE	CURRENT
415V 3Phase	12Amp

Sound Output:	145 dB(A) at 1M
Sound Frequency:	480/560 Hz
Rating:	IP56
Construction:	Aluminium/cast iron
Dimensions():	550mm X 650mm X 600mm
Weight:	142Kg

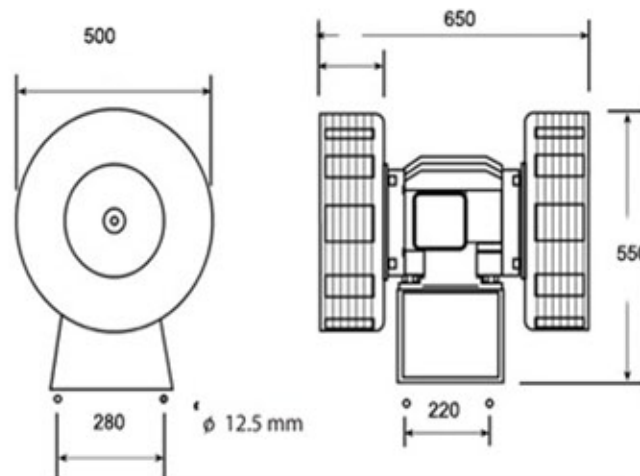

All Dimensions in mm

#### DETAILED SPECIFICATIONS

VOLTAGE	415V 3Phase (Other voltages available on request)
DUTY CYCLE	Continuous
SOUND OUTPUT	145 dB(A) at 1m
SOUND FREQUENCY	480 / 560Hz
APP. RANGE	15000m in still air on open field
MOTOR	7.5 KW motor - 2875 rpm
CURRENT CONSUMPTION*	415 V - 12 Amp
IP RATING	IP 56
WEIGHT	142Kg
PACKING DIMENSIONS	60 x 75 x 70 cm - 150Kg
MOUNTING	The unit should ideally be mounted in a horizontal position. In environments where dirt or particles may fall onto the moving parts of the siren's impellers, it is recommended to place a protective shield above the unit for protection.